



BoonDocker Nitrous System Installation Instructions for Yamaha RX1 Snowmobile with Dual K&N Filters

Before you begin, please read the instructions below and check kit contents

Note: This installation requires two K&N filters, part number **RU-4720** or Yamaha part # GYT-5LP95-01-00 (used for the Yamaha Raptor). When installing these filters, the carburetor main jet size must be increased (for example, from a 132 to a 160 for high elevations, 165 for lower elevations) and the diaphragm springs will need to be replaced with weaker springs or the springs can be cut down to 75mm (3") in length.

Nitrous Kit Contents:

Quality check by:

- | | |
|--|--|
| <ul style="list-style-type: none"> ___ 2 – Nitrous Manifolds with fittings installed, 3 hole nozzle in each ___ 2 – 4-hole nozzles ___ 1 – Nitrous Bottle with valve ___ 1 – mounting bracket for bottle ___ 2 – bottle clamps ___ 1 – high pressure braided hose (1') ___ 1 – 36" length of 1/8" black nylon hose ___ 1 – solenoid ___ 1 – solenoid holding bracket ___ 1 – 1/8" NPT Tee compression fitting for solenoid | <ul style="list-style-type: none"> ___ 1 – 1/8" NPT fitting with Nitrous Filter for solenoid ___ 1 – 4AN adapter for solenoid (fits on nitrous filter) ___ 1 – pushbutton switch ___ 1 – mounting clamp for pushbutton switch ___ 1 – rectifier ___ 4 – electrical connectors – female quick-connect ___ 4 – electrical connectors – butt connector ___ 4 – 1/4" plastic Tee's ___ 2 – 1/4" orifice cup plugs ___ 1 – 2' x 1/4" tubing |
|--|--|

Tools Required:

- Drill + bits (3/4", 1/4")
- Wire stripper / crimper tool
- Side cutters
- 5/32" and 7/32" allen wrenches
- Basic wrench set
- Flat blade screwdriver
- Teflon Tape

Theory of Operation:

A common misconception about nitrous oxide is that it is explosive or flammable. Nitrous by itself does not burn, nor is it explosive. At 565 deg. F, nitrous oxide (N₂O) breaks apart and forms two parts nitrogen and one part oxygen. Inside an engine, this added oxygen speeds up the combustion process (the nitrogen plays an important part in buffering the reaction). Whenever nitrous is used, additional fuel is necessary; otherwise the added oxygen will act as a blow-torch inside your engine. When used properly, nitrous oxide provides the same benefits as turbo charging or supercharging your engine (extra power is made by burning more fuel and oxygen), but without the added cost or complexities.

Below is a diagram of the major components of the Boondocker Liquid Nitrous System. The simplicity of this system makes it the most reliable, easy to tune, and easy to install nitrous system available. By using the existing fuel system (carburetor) to add the required extra fuel for nitrous, the complexity and unreliability of extra components is eliminated.

(continued on next page)

The part that makes the Boondocker nitrous system so unique is our patent pending Nitrous Manifold. This manifold simply mounts on the air box or air filter where it sprays a fine mist of nitrous that is then drawn into the engine through the carburetor(s). This allows the nitrous to be naturally aspirated into the cylinder instead of being forced, which is much friendlier to the motor and allows the nitrous to be used in a much wider range of throttle and rpm settings.

This nitrous manifold greatly simplifies the way extra fuel is delivered that is needed for nitrous use. The carburetor vents are connected to this manifold, allowing the carburetor(s) to breathe normally through the air box when nitrous is not used. When nitrous is sprayed, the manifold produces a positive pressure that goes to the carburetor float bowl, which “pushes” more fuel through the main jet of the carburetor(s). This eliminates the need for an extra fuel pump, fuel solenoid, extra plumbing, and nozzle(s) that are necessary to inject the extra fuel in other systems.

This manifold is also designed to vary the float bowl pressure in relation to nitrous pressure, thus keeping the nitrous and fuel delivery in sync. Fluctuations in bottle temperature greatly affect nitrous pressure, which affects nitrous delivery. By automatically adjusting the fuel delivery as nitrous pressure varies, this manifold makes nitrous safe, reliable, and easy to use.

Be sure to understand and follow the tuning instructions at the end of these instructions. Proper tuning is an important part of any performance-enhancing product.

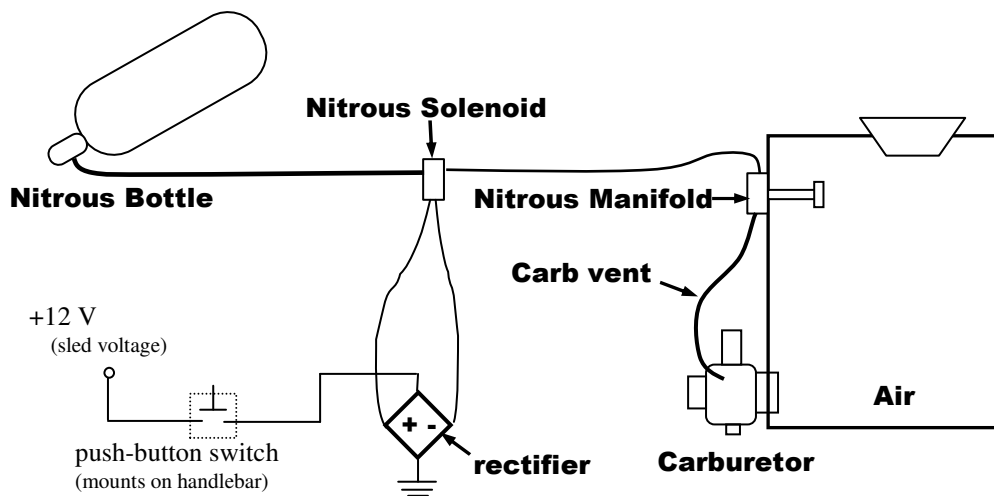

Part I – Bottle Installation

A. Bottle Valve Fittings

Insert the 4AN x 1/8” NPT fitting and the 1/8” NPT Plug into the bottle valve (these are attached to the lid of the box with the bottle). Use Teflon tape to seal the threads – be sure not to get tape inside the threads!

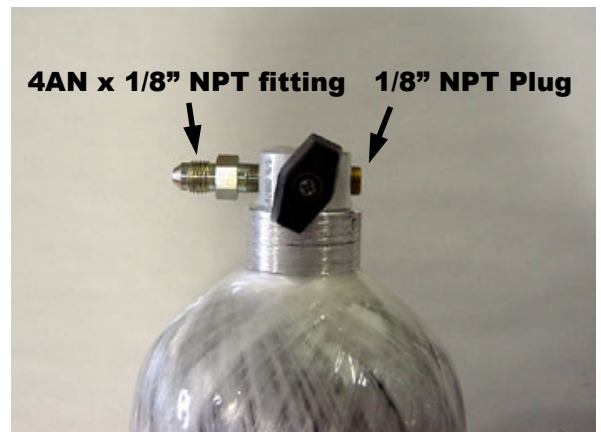

B. Bottle Bracket

Use the existing bolts and nuts to hold the bracket. Make sure the bottle does not touch the engine (bracket may need to be bent slightly for the larger 4.1 carbon fiber bottle and part of the hood may need to be trimmed).

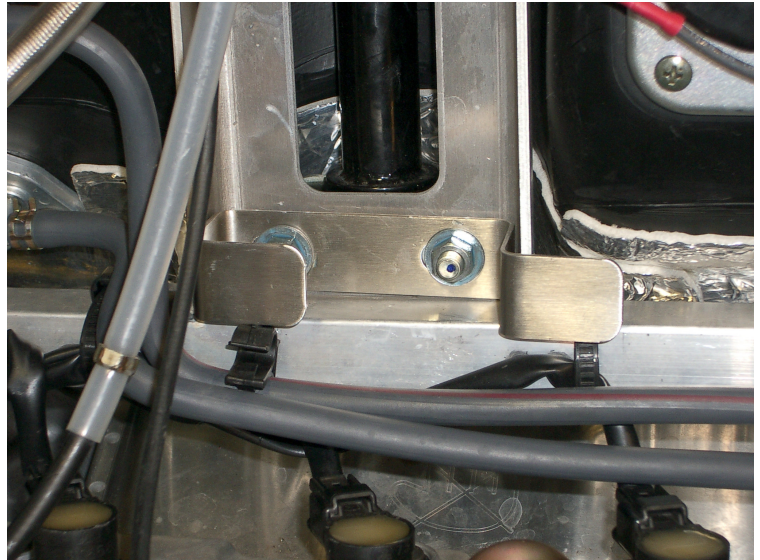

C. Bottle Mounting Position

With nitrous in the bottle, both nitrous liquid and nitrous gas are present under high pressure (760psi at 70 deg F). Due to gravity and acceleration forces, the liquid portion of the nitrous will be at the bottom and rearward parts of the bottle. For this nitrous system to work properly, it is important that nitrous liquid be drawn from the bottle. Nitrous vapor will cause a significant decrease in performance and the nitrous system will not work properly. This bottle contains a **siphon tube** that must be positioned to draw liquid from the bottom/rearward part of the bottle. For the siphon tube to be oriented correctly, the fitting on the valve should be pointed straight towards the front of the sled (refer to picture).



D. Bottle Filling /Weights

Automotive speed shops that sell nitrous kits can usually refill nitrous bottles. This bottle can be filled with non-medical grade nitrous oxide that contains a very small amount of sulfur dioxide (combines with water in your lungs and forms sulfuric acid if breathed too much). This is the same nitrous that is used for all nitrous oxide systems, usually with the name “Nytrosus-Plus”.

Fill the bottle according to the weights below. We do not recommend overfilling the bottle – when the bottle gets hot, it will rupture the blow-off disk.

<i>note: all weights are in fractions of pounds, not ounces</i>	Bottle Size				
	4.1lb CF	4.0lb CF	2.9lb CF	3.0lb AL	2.5lb AL
Weight of Cylinder & Gas	7.8 lb	7.4 lb	6.0 lb	6.1 lb	6.1 lb
Weight of Cylinder Empty	3.7 lb	3.4 lb	3.1 lb	3.1 lb	3.6 lb
Weight of Gas	4.1 lb	4.0 lb	2.9 lb	3.0 lb	2.5 lb

Part II - Manifold Installation

1. Install the nitrous manifolds spaced evenly in front of each carburetor.
2. Separate the stem from the nitrous manifold by unscrewing the bolt in the back.
3. Install the manifold with the stem half inside the airbox and the aluminum half on the outside. Align the two halves together then thread the bolt in so the two halves are tight against the airbox.

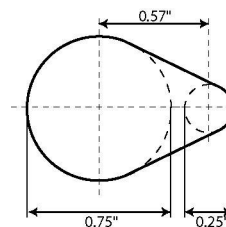
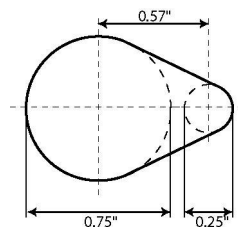
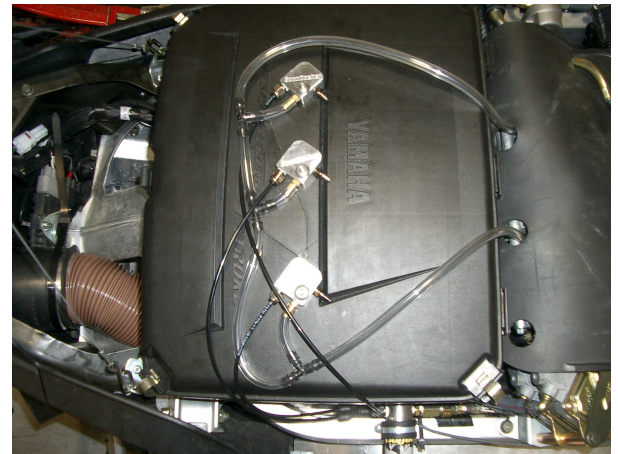

Manifold Cutout Templates

Part III - Solenoid / Hose Installation

1. Before installing the following fittings, apply a thread sealant or Teflon tape to the threads – be careful not to contaminate the insides of these fittings.
 - a. Connect the Nitrous Filter to the side of the solenoid marked “IN”.
 - b. Connect the brass compression Tee fitting to the side of the solenoid marked “OUT”.

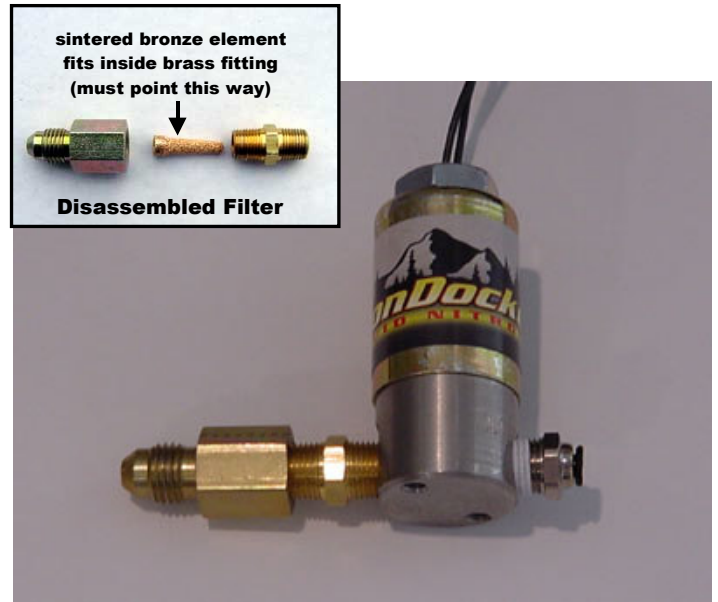

2. Use the cross-brace bolt to hold the padded strap and the solenoid.
3. Connect a 1/8” black nylon line from the solenoid brass Tee fitting to each nitrous manifold. Keep this away from hot items. Note – do not over tighten these fittings! (if over tightened, the compression fitting may constrict the inside of the hose)
4. Connect the high-pressure braided hose from the bottle to the solenoid. These are 4-AN fittings that have matching flanges that form a seal – do not use Teflon tape on the hose fittings (the 4AN fittings form their own seal).

Part IV - Carb Vent to Nitrous Manifold Installation



The nitrous manifold must be able to pressurize the carb float bowl and the carb vent lines must be able to drain if fuel gets trapped in the lines.

1. Connect the carb vent lines to the nitrous manifold as shown. Be sure to connect these vents to the barbed fitting on the bottom of the nitrous manifold.
2. We recommend wire-tying or zip-tying the vent lines onto the fittings. Refer to the diagram.

Part V – Push-Button Installation

The pushbutton switch can be installed on the left handgrip. Shown are directions for installing the button on the left so the button can be pressed with the thumb.

There are two clamps in the kit. The one with the screw is only useful if the button needs to be mounted directly to the handlebar. Directions for mounting the button directly to the handgrip using the crimp-on clamp are shown below:

1. Using pliers, bend a hook into one end of the clamp.
2. Connect the clamp to the button as shown. Fit the hooked part of the clamp to the button so the straight part of the clamp is not connected.
3. Put the button on the left handlebar. With a pen, mark on the clamp where the mounting hole on the button and the clamp meet.
4. Remove the clamp and cut it approximately 1/4" to 3/8" away from the mark. Bend this end with pliers so it is similar to the other hooked end.

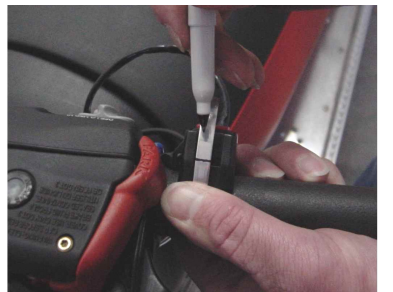
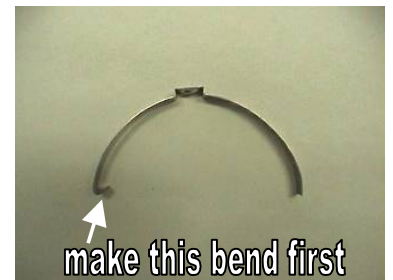

5. Put the button and clamp back on the handlebar. Tighten the clamp with side cutters so it is just snug. Do not over tighten.



6. The button should appear as shown in the picture.



Part VI – Electrical Installation

Wire the connections according to the diagram below. Use a 12V supply that is only on when the ignition key is turned on and the kill switch is in the “run” position.

Most rectifiers are labeled on the side “+”, “AC”, “-”, “AC” (see picture). If the rectifier is not labeled, see the picture below. One of the 4-pronged terminals will be rotated 90 deg. from the other 3. This terminal is “+”, the opposite corner will be “-“ and the remaining two terminals are both “AC”.



rectifier markings on the side

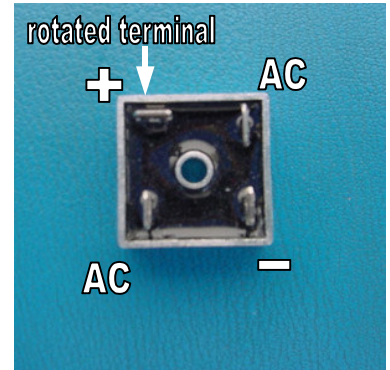
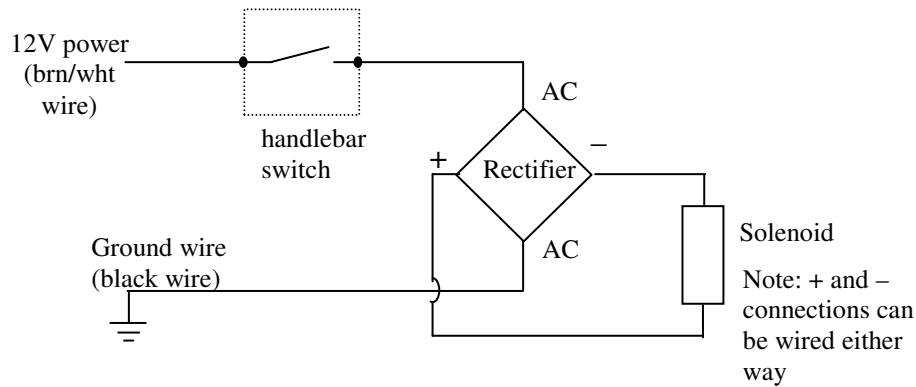

rectifier terminals

Use the brown/white wire for the 12V source and the black wire for ground.

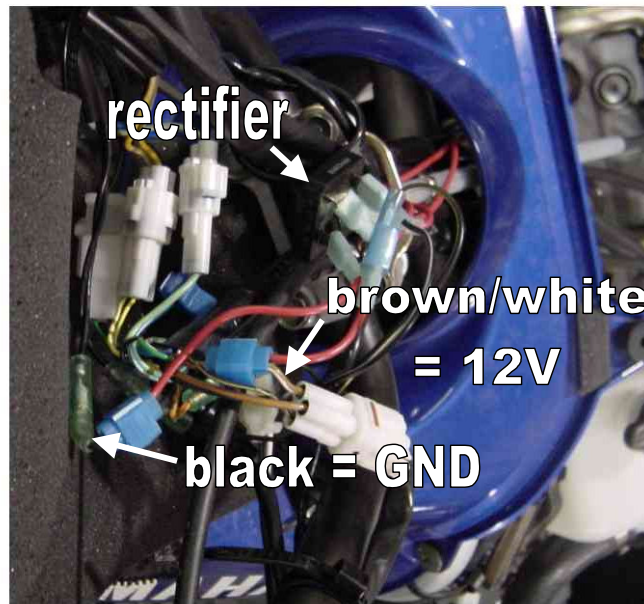

Part VII - Startup and Tuning Procedures

A. Carb Jetting:

Note: The following applies more for air box installations – if K&N filters are used, the jet size will need to be increased anyway.

If your carburetors were originally vented to atmosphere instead of the air box, the main jet size may need to be increased. When a large volume of airflows through the air box, a negative pressure may develop inside depending on how restrictive the air box is. This negative pressure can cause the engine to run too lean unless the main jet size is increased. Make sure the carb jetting is correct before proceeding with the tuning instructions.

Note: A quick check may be performed as follows:

1. With the nitrous manifold installed, run the sled and note performance.
2. Temporarily disconnect the vent lines from the manifold so the carburetors are vented back to atmosphere.
3. Run the sled again and note if performance improves.
4. If performance has improved, you will need to increase the main jet size. Replace the main jets with a larger size, reconnect the vent line to the nitrous manifold and retest. Continue increasing the main jet size until performance is the same as when the vent was disconnected from the nitrous manifold.

B. Important Notes before using Nitrous:

1. We strongly recommend using high-octane fuel (at least 94 for most stock motors, more for modified motors). We have found that race fuel or Boondocker race fuel concentrate mixed with premium gas can provide the necessary octane.
2. We also recommend using one size colder spark plug (higher number = colder). In some cases decreasing the spark plug gap an additional .003”-.005” (to around .020”) achieves best results.
3. Be sure to use filtered nitrous – always use a filter when filling your bottle!
4. When tuning the system, do not use nitrous for more than 2 seconds at a time. Once the system is properly tuned (see steps below), we recommend not using nitrous for more than 8 seconds at a time. If nitrous is used for longer durations, it is critical that the system be carefully tuned and that no detonation problems are occurring.

C. Startup & Leak Test Procedure

The rider must do the following steps every time the bottle is turned on and before doing the fuel adjustment procedure.

1. With the engine off, open the bottle valve and check for leaks. Shut the bottle valve off. With the valve shut, the hose will still have pressure in it.
2. With pressure in the hose and the bottle valve closed, start the engine. Check to make sure the solenoid does not discharge hose pressure.
3. With the engine running (be ready to shut down engine if necessary), open the bottle valve. Push the nitrous button for about one second or less. Engine rpm should increase if the nitrous system is functioning properly.

D. Nitrous Manifold Fuel Adjustment Procedure

There is a fuel adjustment screw on each nitrous manifold. These screws adjust the amount of fuel when nitrous is being used - they will not affect carburetor jetting off nitrous. The “R” marking stands for “Rich” – turning the adjustment screws **in** will add more fuel when using nitrous.

Warning: Only adjust the fuel mixture screws on the Nitrous Manifold according to the steps below.

The factory setting should provide a starting baseline. Each nitrous manifold requires a different number of turns on the fuel adjustment screws to make a given pressure to the float bowls. We recommend you first count the number of turns in each screw is set at before making adjustments. This will provide a baseline you can return to if necessary. If this setting accidentally gets changed and the initial setting is unknown, turn both screws in (clockwise) all the way and then back out 1.5 turns each, then proceed with the steps below.

The steps below should be done with a full nitrous bottle that is at the proper operating temperature (70-90deg F). Make sure the engine is at normal operating temperature. Do not exceed 2 seconds of nitrous use until the fuel adjustment is complete and correct.

This adjustment process should only be performed by an experienced tuner. If you are not an experienced tuner, find someone who is. Remember, safety first!

1. Run the sled in an open area at full throttle and apply nitrous for 1 or 2 seconds. Note engine power and rpms when the button is pushed.
2. Enrichen the mixture by turning the nitrous manifold adjustment screw in (clockwise) 1/2 turn. Run nitrous for 1 or 2 seconds again and note power and rpm difference. If no power loss is noted, repeat step 2 until a loss is noted. A power loss indicates you are rich enough (be sure!) - go to step 3.
3. To find where the mixture starts to become too lean, turn the nitrous manifold adjustment screw out (counterclockwise) 1/2 turn and note power. A power increase should be noted. Turn nitrous manifold adjustment out 1/2 turn and compare to previous run. If no power increase is noted, go to step 4. If power increase is noted, repeat step 3 until no power increase is noted. Use extreme caution - you can go too lean!
4. For the final setting, turn the nitrous manifold adjustment screw back in (clockwise) 1/2 turn.
5. After this adjustment is made, if the engine does not run perfectly smooth when using nitrous, do not use it! If the exhaust note does not sound clean, the cause is likely detonation, which can quickly destroy the engine. Use higher octane fuel, add more ignition retard, reduce the engine's compression, or reduce the amount of nitrous (see next section) before using nitrous again.

Part VIII – Adjusting Amount of Nitrous

It is possible to increase/decrease the amount of nitrous the nitrous manifold sprays by replacing the 3/4" nozzles with nozzles with more/less orifice holes. In general, each orifice hole that is sprayed is equivalent to a 3-5hp increase.

Read this before you increase nitrous!

Be sure your engine is working good before you decide to increase the amount of nitrous. If you are not getting the power increase you are expecting with the original setup, something is likely wrong. Review the manifold tuning procedure and verify that you can tune the manifold so you know there is too much fuel. From there, if leaning the manifold mixture screw does not produce an increase in power, one of the following problems may exist:

1. Be sure your bottle is full, at the correct temperature (70-90 deg), and positioned correctly so the valve picks up liquid nitrous. The system will not work properly if nitrous vapor is being picked up or if the bottle is too cold.
2. Your engine could be detonating. Detonation can occur if your compression ratio is high, your timing has been advanced, or you are not using good octane fuel. Listen carefully to the motor - if it does not sound clean and you are not too rich, you are likely detonating.
3. A bad power source or faulty electrical connection may cause the nitrous system to malfunction intermittently. Carefully check all connections. If necessary, solder all connections.
4. Dirty nitrous can quickly plug the nitrous filter and obstruct the nitrous delivery. Remove and clean the sintered bronze filter element by blowing compressed air through it backwards. Always fill your bottle from a filtered source.

Installing / Removing Nozzles

1. Remove the nitrous manifold from the air box/air filter.
2. Use a 7/32" hex wrench to carefully remove/install a nozzle. Be sure the o-ring is still in place before threading in a new nozzle. Be very careful not to over tighten the plastic nozzle – it needs to be just snug.
3. If you want to increase nitrous delivery, increase the number of nozzle holes by one for each manifold!
4. Retune the nitrous manifold according to the instructions above. Anytime the orifices are changed, the nitrous manifold pressure will change so retuning is necessary.



Part IX – Warranty, Terms & Conditions

Returned Goods – No merchandise will be accepted without prior approval. A RMA number (Return Merchandise Authorization) provided by Boondocker is required before a return will be accepted. A 20% handling and restocking charge will be applied to returned merchandise. No unauthorized returns will be accepted.

Limited Warranty – Boondocker warrants its product to the original purchaser against workmanship defects for a period of 90 days, commencing from the date of product delivery to the Consumer.

Maximum Liability – The maximum liability of Boondocker in connection with this warranty shall not under any circumstances exceed the price of the product claimed to be defective.